

PHILIPS OEM MARKETING

Industry Group Small Computers P.O. Box 245, Apeldoorn, the Netherlands
phone: 05760-30123; telex 4 91 42

PHILIPS

Philips mini computers P850 / P855 / P860

Full details can be had from the above address or:

EUROPE

Sweden
Svenska AB Philips Data Systems
Fack 183 03, Täby 03,
Stockholm,
Tel. 756 0020

Denmark
Philips Electrologica A/S
Prags Boulevard 80
2300 Kobenhavn S,
Tel. 2222

Norway
Norsk Aktieselskap Philips
Sorkedalsveien
Postbox 5040
Majorstua Oslo 3,
Tel. 463890

Finland
OY Philips AB
Kaivokatu 8
Helsinki 10
Tel. 10915

Belgium
NV Philips-Electrologica
Anspachlaan 1
1000 Brussel,
Tel. 193900

France
Philips M.E.P.
Division Ordinateurs
5, Square Max Hymans
75, Paris 15e,
Tel. 734 7759

Western Germany
Philips Electrologica GmbH
Geschäftsbereich Computer-Systeme
Liesegangstrasse 15
4 Düsseldorf,
Tel. 360361

Italy
Philips S.P.A.
Divisione Sistemi
Viale Fulvio Testi, 327
20162 Milano,
Tel. 6420951

Switzerland
Philips AG
Edenstrasse 20
8027 Zürich
Tel. 442211

The Netherlands
Philips-Electrologica Nederland NV
De Horst 4 (Postbus 2408)
Den Haag - Mariahoeve,
Tel. 814571

England
M.E.L. Equipment Company Ltd.
Manor Royal,
Crawley,
Sussex,
Tel. 0293 28787

NORTH AMERICA
U.S.A.
North American Philips Corp.
Dept. 007
100 East 42nd Street,
New York N.Y. 10017
Tel. 212 697 3600

FAR EAST
Japan
Philips Industrial Development
and Consultant Co. Ltd.
Kokusai Building 7th floor,
1-1, 3-Chome Marunouchi, Chiyoda-Ku,
Tokyo 100
Tel. 213 6752 9

NV Philips-Electrologica reserves the right to make any necessary changes in the contents of this publication without prior notice. The policy of the company is one of continuous improvement.

© by NV Philips-Electrologica, 1971

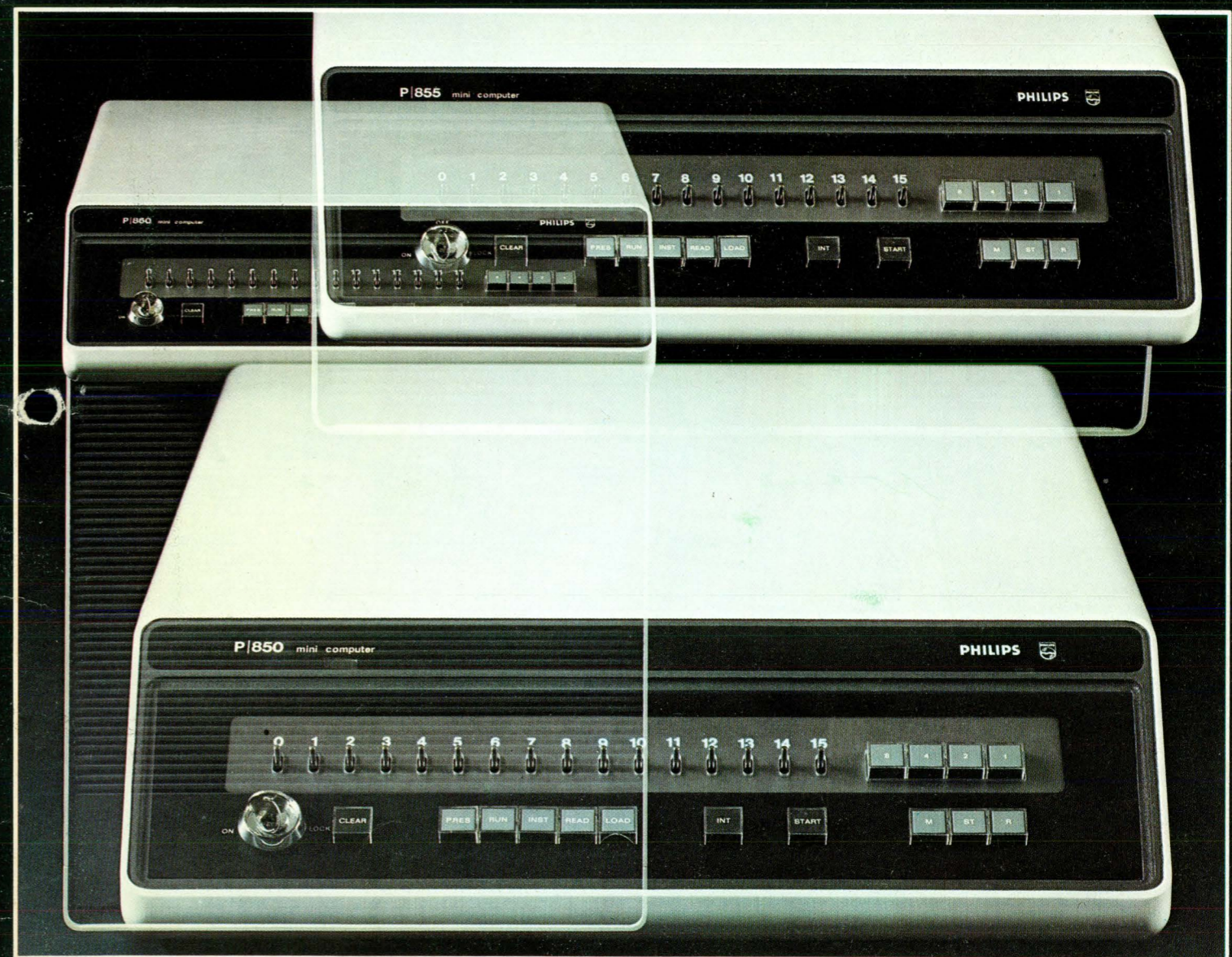

data systems

P800 series

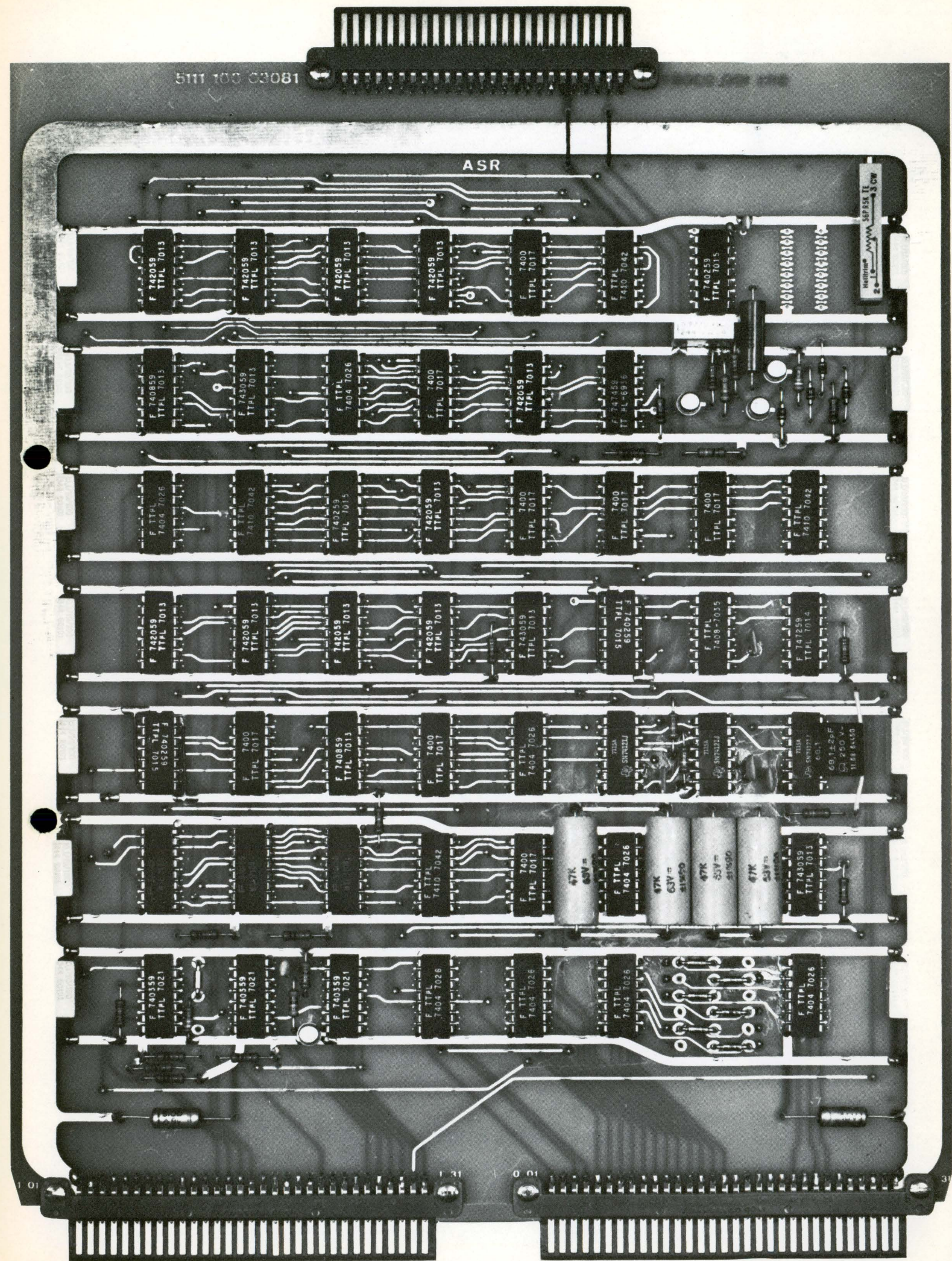

I want more information about

P850 **P855** **P860**

Name

Position

Company

Address

I want more information about

P850 **P855** **P860**

Name

Position

Company

Address

I want more information about

P850 **P855** **P860**

Name

Position

Company

Address

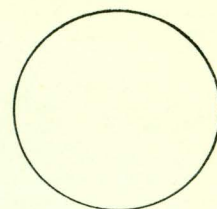

NV Philips-Electrologica,
OEM Marketing Division,
P.O. Box 245,
Apeldoorn, the Netherlands

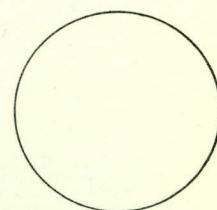

NV Philips-Electrologica,
OEM Marketing Division,
P.O. Box 245,
Apeldoorn, the Netherlands

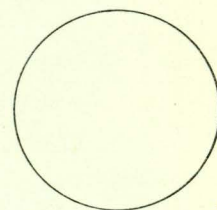

NV Philips-Electrologica,
OEM Marketing Division,
P.O. Box 245,
Apeldoorn, the Netherlands

instruction set

Mnemonic Description

Memory reference instruction

LD	Load register
ST	Store register
AD	Addition
SU	Subtract
AN	Logical and
OR	Logical or
XR	Exclusive or
IM	Increment memory
C2	Two's complement
* ML	Multiple load
* MS	Multiple store
ABI	Absolute conditional branch
CFI	Call function
C1	One's complement
CW	Compare word
* CC	Compare character
LC	Load character
SC	Store character
RF	Relative Forward conditional branch
RB	Relative Backward conditional branch
** MU	Multiply
** DV	Divide
** DA	Double Add
** DS	Double Subtract

Register to register instructions

LDR	Load register/register
STR	Store register/register
ADR	Addition register/register
SUR	Subtract register/register
ANR	AND register/register
TM	Test Mask
TNM	Test Not Mask
ORR	OR register/register
XRR	XOR register/register
IMR	Increment memory/register
C2R	Two's complement register
* MLR	Multiple load/register
* MSR	Multiple Store/register
ABR	Absolute conditional branch/register
CFR	Call Function/register
C1R	One's complement register
CWR	Compare word register/register
* CCR	Compare character/Register
LCR	Load character/Register
SCR	Store character/Register
RTN	Return
ECR	Exchange character register/register
** MUR	Multiply
** DVR	Divide
** DAR	Double Add
** DSR	Double subtract

Constant instructions

LDK	Load constant
ADK	Add constant
SUK	Subtract constant
ANK	Logical and with constant
ORK	Logical or with constant
XRK	Exclusive or with constant
* MLK	Multiple load constant
AB	Absolute conditional branch

CF	Call function
CWK	Compare word with constant
* CCK	Compare character
LCK	Load character
** MUK	Multiply with constant
** DVK	Divide with constant
** DAK	Double add with constant
** DSK	Double subtract with constant

Shift instructions

* SLA	Shift left arithmetic
* SRA	Shift right arithmetic
* SLL	Shift left logical
* SRL	Shift right logical
* SLC	Shift left circular
* SRC	Shift right circular
* SLN	Shift left normalize
* SRN	Shift right normalize
* DLA	Double length left arithmetic shift
* DRA	Double length right arithmetic shift
* DLL	Double length left logical shift
* DRL	Double length right logical shift
* DLC	Double length left circular shift
* DRC	Double length right circular shift
* DLN	Double length left and normalize
* DRN	Double length right and normalize

I/O Instructions

CIO	Control I/O
INR	Input to register
SST	Send status
OTR	Output from register
TST	Test status
** WMP	Write Mask Protection
1 WM2	Write mask 2
RIL	Read Interrupt Line
WIM	Write Interrupt Mask

Miscellaneous instructions

ENB	Enable interrupt
HLT	Halt
RIT	Reset internal interrupts
INH	Inhibit interrupt
LKM	Link to monitor
* SMD	Set mode

* P860 only - standard *and P855*

** P860 only - option *and P855*

° These instructions are available with the P850 but will only shift one position.

1 This is for use with P860 machines with greater than 16k store.

The P850 is our least expensive member and sets a new standard for low prices. It combines TTL technology with medium scale integration to achieve new levels of reliability, price and performance. It is the best computer for its price distributed world wide. With a full cycle time of 3.2 μ sec it exceeds the requirements of most applications. A complete repertoire

mathematical library, drivers for all peripheral equipment and a complete range of diagnostics and utility routines. All software packages are designed to be compatible with each member of the family and the executive systems expand in capability with the amounts of storage available, thus making full use of each of our progressively faster products.

philips presents a new family of mini computers: P850/P855/P860

of arithmetic instructions is available in its instruction set. It is the ideal computer where low price, moderate memory requirements and ease of interface are the paramount parameters.

The P855 is faster; memory cycle time is down to 1.6 μ sec and the basic cycle time down to 720 nanoseconds. The store has a larger range for larger applications. I/O has also been improved to give impressive possibilities. The P855 provides an optimum medium price solution to a wide range of industrial automation problems.

The P860 is even faster. Memory cycle time is down to 840 nanoseconds. Store sizes range up to 32k 16-bit words. Software, hardware and I/O possibilities are comparable with large machines.

All models have 16 16-bit registers; 14 general purpose ones, an instruction counter and a stack pointer. These registers contribute greatly to the overall efficiency of the machine. The basic instruction set is comprehensive. It is increased on the P855 and P860 by the high speed arithmetic option, which includes multiply, divide, double add and double subtract.

Software available includes two FORTRAN compilers, a basic monitor, a real time monitor, two one-pass assemblers, a mini assembler for our P850, linking loaders, edit routines, complete

The peripheral equipment available with these machines ranges from teleprinters, cassette tapes and plotters through data communication equipment and a full range of controllers and interface capabilities to high speed devices such as line printers, discs etc. It is all upward compatible. Any piece of equipment that works with the P850 can be plugged into the P855 or P860 without problems. The range of peripherals increases with the larger machines, because they can make better use of them. It is also possible to connect custom devices without difficulty.

Options available with this series include Real Time Clocks, Direct Memory Access, Memory Incrementing Channel for analytical work, analog and digital I/O systems, a Memory Protect feature, a multilevel interrupt facility expandable to 48 levels, and many others.

To increase the scope of this family, each machine is available in a range of memory capacities, cabinet sizes and peripherals. The outward appearance can also be changed: rack mountable for industrial environments and an attractively designed table top cabinet for office applications. The control panel, available in a mini or full option, can also be purchased separately. This enables the control and setting up of a large number of separate computers with a single panel. The P800's all come with the world wide back-up of Philips.

P850

specifications

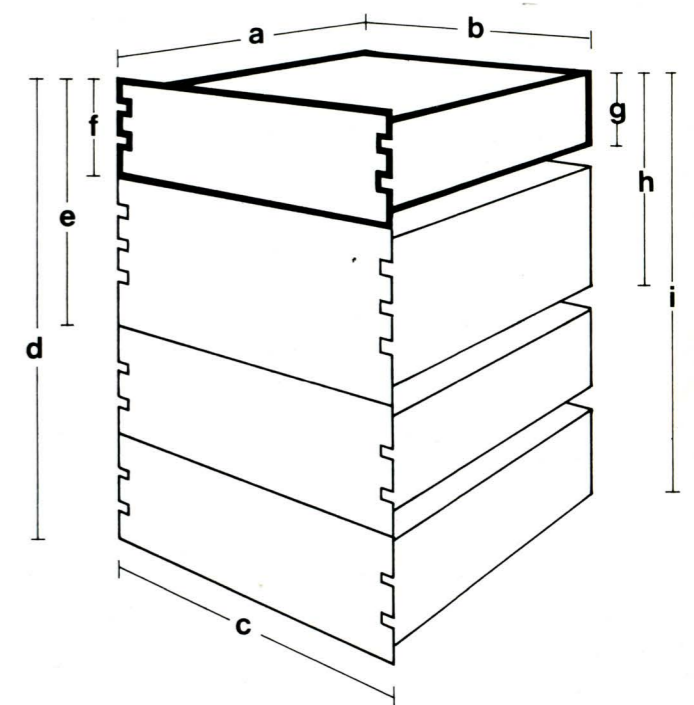
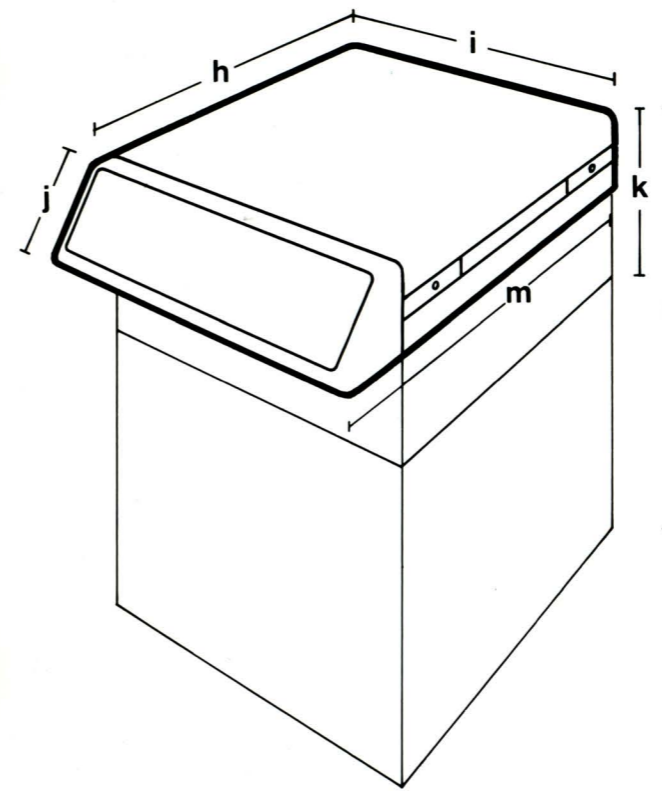

Stand alone

h = 568 mm
 i = 545 mm
 j = 181 mm P850
 k = 425 mm P855/P860
 l = 742 mm P860
 m = 715 mm

Rack mountable

a = 540 mm
 b = 440 mm
 c = 483 mm
 d = 622 mm
 e = 356 mm
 f = 133 mm
 g = 130 mm P850
 h = 353 mm P855/P860
 i = 619 mm P860

Power and environment.

These requirements apply to the central processor. Special peripheral equipment must be allowed for when planning the system.

Voltage: 100, 115 or 220 volts \pm 10%

Frequency: 50 \pm 2 Hz or 60 \pm 3 Hz.

Transients: 2Kv peak, 100 microsecond maximum duration measured at half peak voltage points and 1 second repetition rate.

Temperature:

operating 0 - 45°C , 32 - 113°F

non-operating -30 - 70°C , -22 - 158°F

Temperature change:

operating 0.5°C or 1°F per minute.

non-operating 1°C or 2°F per minute.

Relative humidity: 0 - 85%

services

Philips, one of the leading 'Fortune 500', is one of the largest manufacturers in the world. It has a tremendous reputation for quality products and complete customer service. These traditions are carried right into the field of minicomputers.

Not only is Philips service first class, but it is world wide. The sign of Philips is a common sight in every country. Wherever these mini's go, Philips is there already. The truly multinational aspect of Philips is an important factor in providing the type of service which should go with professional products. Philips engineers speak all languages. They provide a truly international service, wherever they are required.

Documentation is also of great importance. It has to be as detailed as required and it has to be always up to date. This is normal practice at Philips. Being such a multinational firm, documentation is also available in many languages.

Supporting the documentation and service is a world wide parts organization. We offer a complete range of control units. We also offer blank PC cards, predrilled to make it easy for clients to assemble their own custom interfaces.

The whole family is very flexible and easy to interface to user's equipment.

OEM discounts are extremely competitive.

To sum up; Philips is a natural choice for the OEM customer. In both product and company we offer an unbeatable combination.

the price/performance leader

The P850 was designed to be the world's best low cost minicomputer. It is a reliable, very inexpensive, easy to interface mini computer. The smallest version of the P850 is an amazing machine for its size. It provides a full 16-bit word memory of 500 word capacity, as well as a complete instruction set and room for a wide selection of additional controllers and interface cards. The memory is expandable in 500 word modules.

All the P850 store sizes have a cycle time of 3.2 microseconds. Well proven techniques make this one of the most reliable machines in existence. The P850 is the first of the line. Everything that works on the P850 can be transferred to one of the larger models, software or peripherals without problems.

In its standard form the P850 is available in either rack mountable or table top versions with a range of control panel options. Included in this range is a fully disconnectable control panel. The P850 cabinet is available in at least two sizes for either rack mountable or table top options. The small version can hold up to 1k words of store plus two controllers. The expanded cabinet can hold the whole range of the store plus up to nine controllers or Input/Output cards.

Expansion is very simple. Options available include a real-time clock, a power failure/automatic restart feature, a digital I/O system for high voltage equipment and an analog/I/O system.

Taking into account the size, the

performance, the amazingly low price and the fact that it operates in industrial environments, the P850 becomes a very interesting computer.

P855

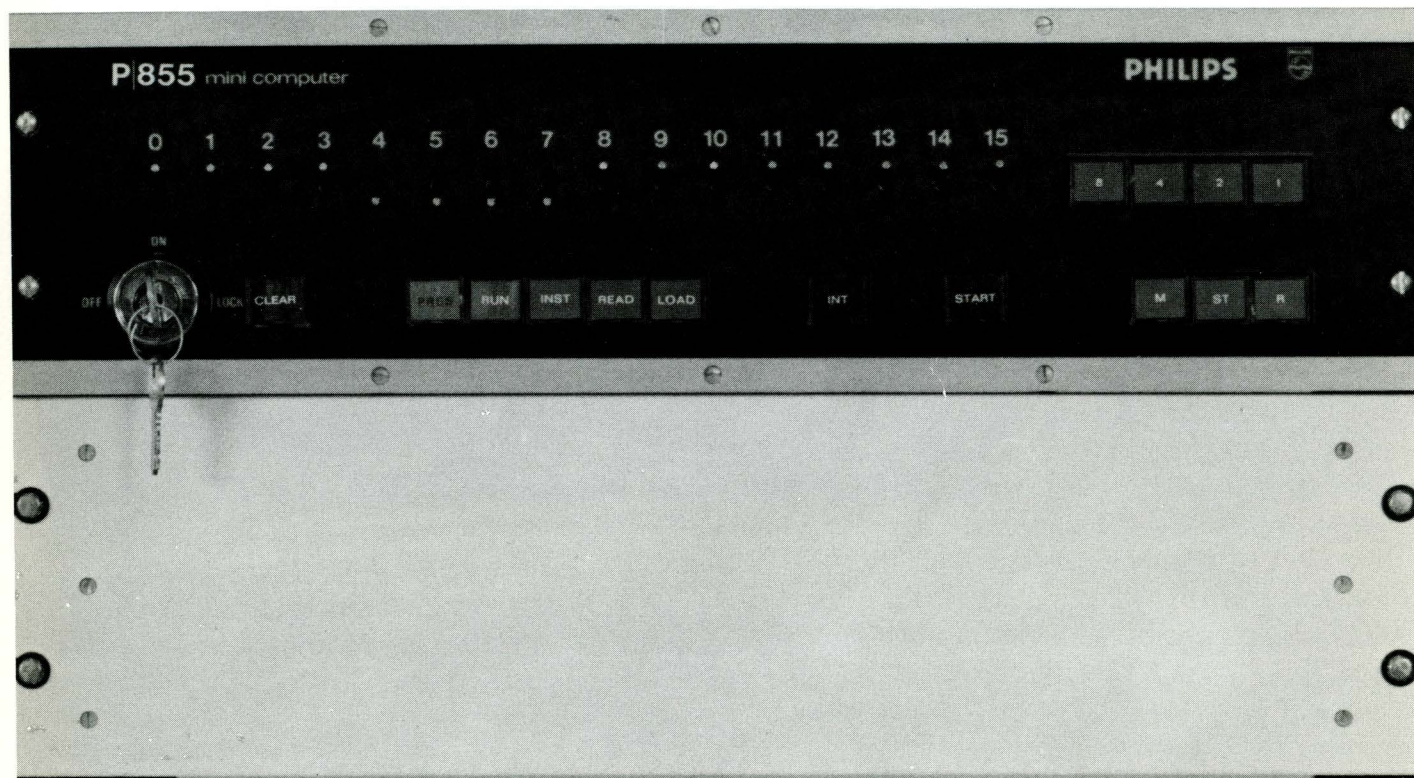

interfaces

DIOS. Digital I/O System is a simple circuit board that plugs into the I/O bus circuit. It enables the connection of higher voltage devices such as relays.

Analog/digital I/O system. This is a rack mountable system that connects easily into the I/O bus circuit.

Circuit boards. Custom interface capability is facilitated by the use of blank circuit boards which connect directly into the P800 series CPU.

Data communication. Three types of data communication control unit are available: asynchronous single line control unit, synchronous line control unit and the multiple low speed line control unit.

options

All models

Power failure automatic restart. Valuable feature which senses power drops and enables programs to halt in a logical place. It will restart when power returns to normal.

Real time clock. Provides an interrupt every 20 ms in response to a standard timing signal. Other timing intervals are available.

P855/P860

Multiplex channel. Designed for greatly increased input and output. Transfer speeds of 60,000 words a second on the P855 and 120,000 on the P860.

Direct Memory Access. Greatly lowers channel request handling time, because it can interrupt the processor in the middle of an instruction.

Memory Increment Data Break. Possibility of incrementing memory locations without affecting the central processor. It makes analytical processing very efficient.

Memory protect feature. Provides instruction and memory protection and allows a number of programs to share processor time.

High speed arithmetic. This package includes hardware multiply, divide, double add and double subtract.

peripherals

All models

Teleprinter - ASR 33, ASR 35 and KSR. Keyboard and printer incorporating tape reader and punch. Operating speed 10 characters a second.

Tape reader. Fast, modern, 8-channel tape reader. Operates at 333 characters a second.

Tape punches. Choice of two reliable, 8-channel tape punches; fast and faster. Operate at 75 and 150 characters a second: stand alone model and rack mountable model, respectively.

Card reader. Photoelectric card reader that operates at up to 300 cards a minute.

Character display unit. Keyboard simple to use; good for setting up blocks of information; special controls. Output from system displayed at high speed on easy to read screen. Operates at up to 1200 characters a second.

Magnetic cassette tape unit. Two track serial tape recorder with a capacity of 338,000 characters and a transfer rate of 3000 bits per second. It accords to the ECMA standards.

Plotter. Well proven plotter with a step of 1mm. Can operate at 300 steps a second in 8 directions.

Line printers. Two models of line printers with 80 or 132 print positions. Minimum speeds 356 and 245 lines a minute respectively.

P855/P860

Magnetic tape unit. The same type that is already used on several large computer

systems. Density of 800 bits per inch and tape speed of up to 37.5 inches per second.

Fixed head discs. Capacities of 25, 50, 100 and 200 thousand words. Access time only 10 milliseconds average, and transfer rate is 200,000 characters a second.

Moving head disc. Capacity of 2.7 million characters. Access time is only 165 milliseconds average and transfer rate is 50,000 words a second.

Interrupt system

Program interrupts are either internal CPU or generated by the peripherals.

Internal interrupt sources are:-

- * Power failure/automatic restart
- Control panel
- Operation code (non-wired instruction, link to monitor or stack overflow)
- * Memory protect error (address error or illegal instruction)
- * Real time clock
- * indicates an optional feature.

These conditions are activated by flip-flops and are reset by RIT instructions in the corresponding interrupt programs. External interrupts are reset by the normal I/O instructions.

getting faster

Some applications call for a mini with a better performance than the P850. They need the P855.

The P855 is a fully parallel 16-bit, multi-accumulator, general purpose mini computer. It has a 1.6 microsecond cycle time and a 500 nanosecond access time. Store size can be 4k, 8k, 12k or 16k 16-bit words. There are two cabinet sizes, both available in table top or rack versions. 4k or 8k memories plus 4 controllers mount in the small version, and the whole range plus up to 11 controllers in the larger version. A full range of I/O equipment is also available.

Important options are: Direct memory access, Multiplex channel, Memory increment data break, Memory protect plus all those available with the P850. Thus there is a better channel request handling time, a higher data throughput and the possibility of analytical work.

Additional peripheral possibilities include moving and fixed head disc units.

The instruction set and the software have both been increased; the instruction set by double length and multiple shift instructions, amongst others, and the software has been increased by a sophisticated debugging program, the FORTRAN compiler, Real time Monitor and linking loader. Like the P850, the P855 is available as rack-mountable or stand-alone with a choice of control panels.

If you need a mini with better performance

than the P850, it is good to know that you can buy this machine and still stay with Philips.

P860

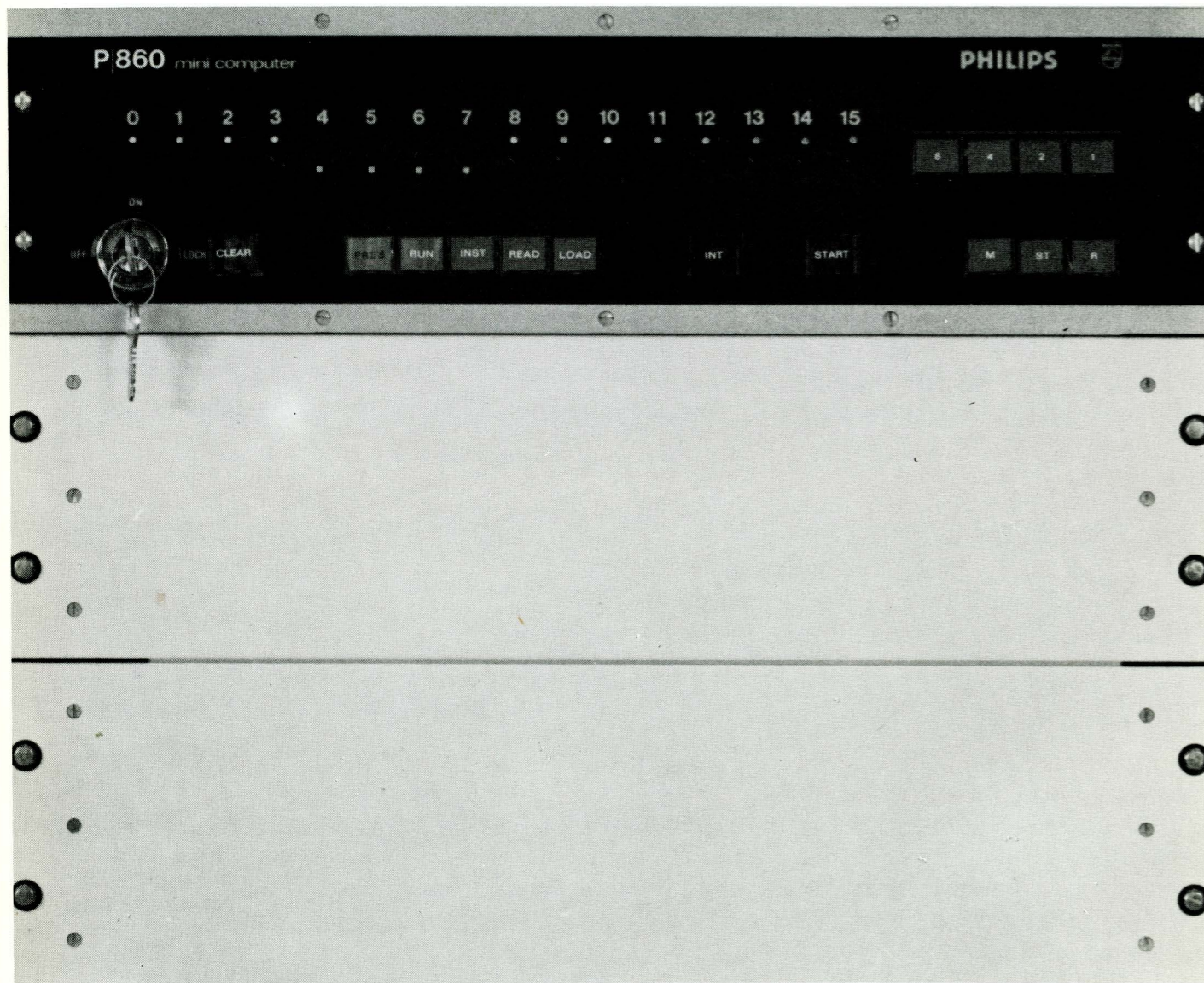

task is active.. The memory protection feature can be utilized for a very high degree of program security. Fast fixed head disc can be used to store disc resident programs.

Linking loader. This only takes one pass. It link edits absolute or relocatable object code programs; link loads object programs, specifies unsatisfied external references and enables conversational control of processing. It accepts object code from Assembler or the FORTRAN compiler.

Text Editor. This allows the alteration, deletion and insertion of a character, group of characters, a line or a group of lines. The work is performed on pages of text which are held in core during an editing session. There are 17 elementary instructions, ranging from 'reading a page into core' to a 'string search when the required string is not found on the specified page'. There are also 6 special action characters for certain operations, plus an auxiliary file feature for moving large portions of text.

8k Disc Operating System. This keyboard oriented operating system allows program generation and testing. The required moving head disc holds, in addition to user files, all the system software components including Text Editor, Assemblers and compilers, Linkage Editor and Debug Program.

Instruction formats

Format 0: Constant handling instructions

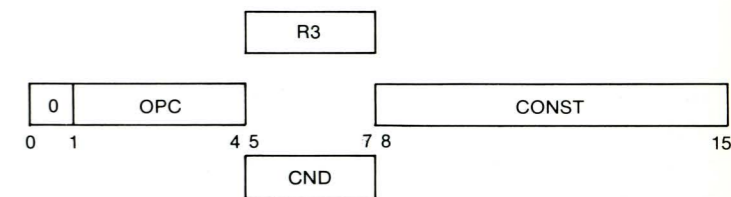

- OPC - Operation code
- R3 - Register on which operation has to be performed; can be any of the first 8 general purpose registers.
- CND - Indicates condition for relative branches (coded in OPC)
- CONST - 8-bit positive constant or displacement for branches. In some instructions this can be used as an OPC extension.

Format 1: Memory reference or register to register instructions.

Short:

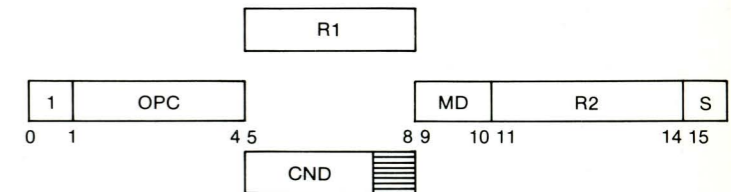

- OPC - Operation code
- R1 - Specifies which of the 16 general purpose registers the operation is to be performed on.
- CND - Same as format 0 instruction but bit 8 is not used.
- R2 - Register number (1-14) relative to the second operand or to its address.
- MD - Addressing mode.
- S - This is used for memory reference instructions. If S = 0, the result goes to R1. If S = 1, the result goes to memory.

Format 1.

Long:

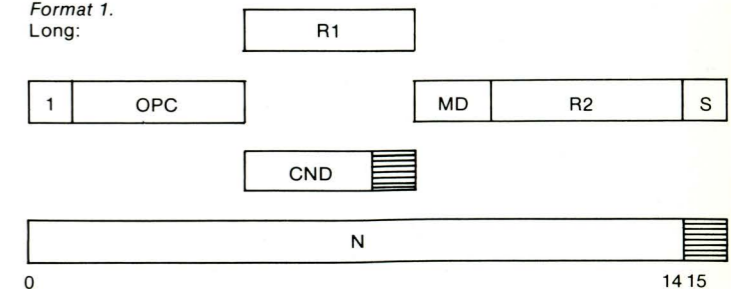

This is the same as the format 1 (short) instruction, except:

- R2 - Register number (0-14) relative to the second operand or to its address (for instance, as an index register).
- N - Constant, store address or displacement.

software

the big little computer

P850

Executive System. Contains a bootstrap loader for loading programs in absolute object code format; a program loader; utility routines for a binary or hexadecimal core dump; I/O routines for reading and writing in binary or ASCII; interrupt handling routines; and hardware simulation routines for multiply, divide, double add and double subtract.

2k stand alone Assembler. Input is in Assembler source language; output is in relocatable object code. Acceptable directives are - IDENT, EQU, RES, AORG, RORG, END and DATA. There is an optional listing suppression and normal 'Halt on error'.

Stand alone update package. This can update source text or object libraries; delete or insert source lines; and insert or omit object modules.

P855/P860

4k stand alone Assembler. This is a one pass assembler that outputs absolute or relocatable object code. Facilities are as follows; external references allowed, non-permanent update, non-fatal error recovery procedure, optional inclusion of symbol table in generated code, double buffered I/Os for configurations greater than 4k.

Acceptable directives are - ENTRY, EXTRN and COMN for linkage control, plus IDENT, EQU, RES, (N)LIST, AORG, RORG, STAB, END.

8k Macro Assembler. This is an extended

version that provides macro and conditional assembly features. The additional assembly directives are: FORM, XFORM, GEN, EJECT, IFF, IFT, and XIF. *Debug program.* Interpretive debugging facilities are available to allow the user to trace the execution of his programs and perform extensive diagnostic procedures.

4k FORTRAN compiler. This is an improvement on basic USASI FORTRAN. It is a one pass compiler that generates object codes in standard machine object language.

8k FORTRAN compiler. This complies with USASI FORTRAN IV standards.

4k Basic Monitor. Available on P855 or P860. Single task supervisor with I/O handling and a subset of the system macro calls available on the larger real time monitor. Usable at program generation time as well as at run time. It includes scheduled label facility.

8k Real Time Monitor. This is a multitask system that utilizes 48 hardware interrupt levels and 16 software priority levels. The system handles all I/O requests and interrupts. Facilities are available via operator command or system macro calls. They include the ability to connect programs to software levels and timers, allowing multitasking and program activation under control of a timer. I/O handling is done by the monitor, a wide variety of functions being available. A background area can be defined to utilize spare CPU time when no foreground

Applications that needed big computer performance nearly always had to have a big computer, until now. Now they can use the P860; a genuine mini-computer with endless possibilities. The small version can hold 4k or 8k of store plus 4 controllers. The larger version can hold 4k, 8k, 12k or 16k of store, up to 11 controllers plus a further cabinet extension for an additional 16k of store. The cycle time is 840 nanoseconds for 16 bits and the access time is only 300 nanoseconds. This puts the P860 right into the large computer field at a minicomputer price. It has many features that are found in large computers all over the world: TTL, medium scale integration, multiplex channel, fully parallel etc. The memory is one of the fastest available for the price, using modern yet well proven techniques. The software is completely compatible with the P855. Peripheral equipment possibilities are the same as those for the P855: options include all those supplied with the smaller machines. Like the others in the range, its outward appearance has a variety of choices. However, all cabinet sizes take the same floor area, so changing to a larger or a smaller machine presents few problems. The P860 is a real improvement on the other members of the range in terms of store size and speed. For the extra money you get a lot more computer. The others are very good but this one is the best.

